

# Design Of Bidirectional DC-DC Converter For E-Mobility

G Madhuri

Assistant Professor, Department of EEE, Vignan Institute of Technology and Science, India.

Email-Id: gottipati.madhuri@gmail.com

D Bhanuchandar

PG Scholar, Department of EEE, Vignan Institute of Technology and Science, India.

Email Id:dabbikarbhanuchandar@gmail.com

**Abstract:** A bi-directional buck-boost DC-DC converter and its control are presented in this paper for vehicle charging and vehicle-to-grid (V2G) energy transmission. With a greater intermediate DC bus voltage, the cascaded buck-boost design permits overlapping input and output voltage ranges. To increase the converter's transient performance, the intermediate DC-link capacitor voltage is changed. This capacitor's reference voltage is determined by the input and output voltage levels, as well as the power requirement. Simulation and tests were used to assess the converter's modularity, control flexibility, and transient performance. In certain ways, each of the converter topologies has an advantage over the others. For practical applications, feasibility studies have been conducted. To back up the theoretical conclusions, simulation and experimental data are presented for both converter types. Innovative topologies for the power converter system have resulted from hybridization with various electric energy sources and the use of various auxiliary outputs in PEV applications. For PEV applications, this thesis offers a unique bidirectional DC-DC converter with multi-input and multi-output capacity. With the existing controller, a control algorithm has been developed. For the converter system, I designed and constructed a system. To increase the overall system efficiency, a passive auxiliary circuit was utilised to allow soft switching approach in the multiple input condition. To underline the control strategy, simulation and experimental findings have been presented.

**Index Terms:** DC-DC converter, vehicle-to-grid, PEV, control strategy, buck-boost

---

Manuscript received January 12,2022; Revised February 9, 2022; Accepted March 1, 2022.

## I.INTRODUCTION

### A. *The electric vehicle:*

Although the electric vehicle (EV) may seem to be a recent innovation, its roots may be traced back to the nineteenth century. nyos Jedlik, a Slovak-Hungarian priest, created the first electric vehicle in 1828. It was a toy automobile that was propelled by an electric motor [1]. The motor was made out of a rudimentary arrangement of electromagnets that were successively switched by commutators, resulting in poor power and efficiency.

EVs using electromagnet-based motors and electrochemical cells as a power source have been developed in the past. Despite their limitations, they outperformed the internal combustion engine (ICE) vehicles, which were initially conceived in 1826 by American inventor Samuel Morey.

Gaston Planté in 1859 made further advancements with the use of a lead-acid rechargeable battery. Furthermore, innovations offered by ZénobeGramme in 1873 boosted the efficiency of DC electric motors [2]. The first commercial electric car was built in 1893. Paul Pouchain's concept was capable of transporting six persons at a speed of 16 km/h. EVs outnumbered ICE automobiles until the 1910s. However, Henry Ford's introduction of mass manufacturing of ICE cars in 1910 and Charles Kettering's creation of the automotive starter in 1920 put an end to the EV's dominance over ICE vehicles. Furthermore, large-

scale oil production, which began in 1920, provided ICE cars with a longer driving range at a cheaper cost of manufacturing. This combination of problems made EVs less appealing [3], and their usage was severely limited after the 1920s.

Following the 1973 oil embargo, interest in EV resurfaced because to pricing and energy supply concerns [4]. Furthermore, there is rising worry about ICE cars' environmental impact, as well as the ever-increasing energy demand and the depletion of fossil resources [5]. As a result, numerous governments have enacted policies to encourage the development and purchase of electric vehicles [6]. As a result, EVs are a viable option, despite the fact that certain technical issues must be addressed [7].

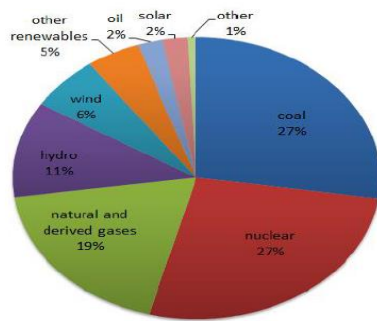

Figure 1. Energy consumption by electric source.

### B. Currently in use

Commercially accessible HEVs and EVs are now available. Unlike EVs, which are totally powered by the battery, HEVs use the battery in a more or less intense manner, depending on the type. The following degrees of hybridization may be distinguished based on the penetration of electrical energy in the HEV design, i.e. the power ratio between the ICE and the electric machineries [14]

### C. Micro HEV

The electric motor has a lower power rating (1.5 to 3 kW [15]) and is solely utilised as an alternator during start-up, with the engine providing propulsion. The efficiency boost comes from the start-stop technology, which stops the engine every time the vehicle comes to a halt. Ford Fiesta and

Honda Civic are two examples of mini HEV automobiles.

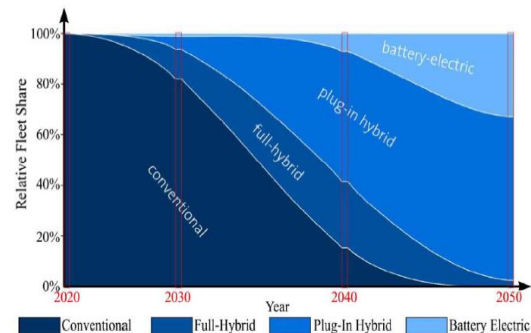

Figure 2. Predicted vehicle fleet comparison.

### D. Mild Hybrid

HEV with a low power rating is known as a mild HEV (10 to 20 kW). The electric machine may give additional power during accelerating or braking in addition to the start-stop capabilities. Regenerative braking is the sole way to replenish the battery. Two mild HEVs are commercially available: the Peugeot 308 e-HDi and the BMW Active Hybrid 7.

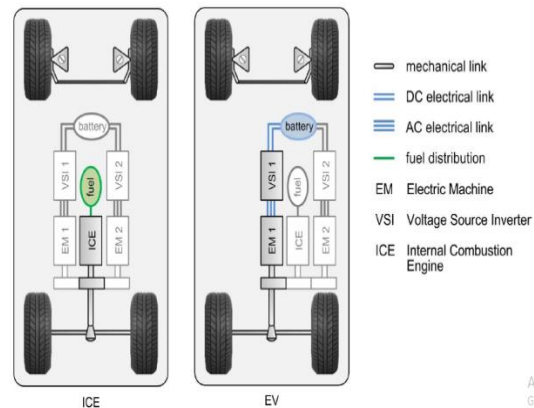

Figure 3. ICE and EV architectures.

### E. Full Hybrid

The electric motor has a medium to high power rating (40 to 80 kW), enabling the vehicle to operate entirely on electricity based on its speed and the state of charge of the battery (limits vary by model).

Using the architecture of power train, the EVs are classified as

#### F. Parallel HEV

The vehicle may be driven by the engine, the electric machine, or both at the same time in a parallel HEV. The electric machine and the engine must be mechanically connected in order to do so. When travelling at consistent high speeds, this design is very efficient since the engine operates at its most efficient level and the electrical machine provides additional power when **needed**.

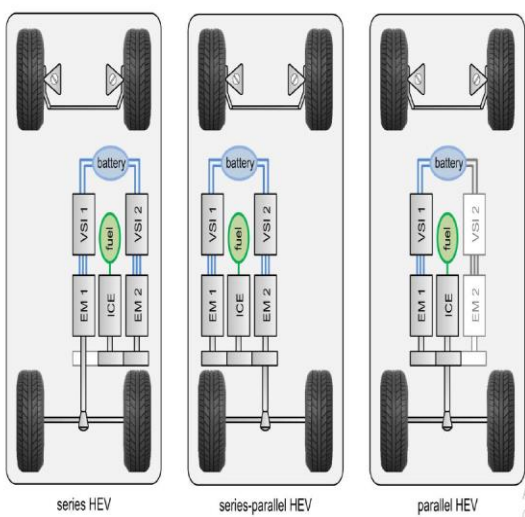

Figure 4. HEV architectures.

#### G. Series HEV

The vehicle is propelled by an electric motor that is powered by a battery. Depending on the driving circumstances, the engine is paired with another electric machine that acts as a generator and charges the battery while the vehicle is in operation. Because the motor does not operate while the vehicle is stopped, and starting an electric motor uses less energy than starting an engine, this design is more economical in urban driving cycles with frequent stop/start movements.

#### H. HEV with series-parallel design

This architecture allows the vehicle to function as a parallel or series HEV. As a result, a

planetary gear unit must mechanically connect the two electric machines and the engine.

The various HEV designs, as well as an ICE and an electric car, are shown in Fig. All of the designs may be thought of as a modified version of the series-parallel HEV architecture with certain components deleted.

These architectures do not immediately match to any of the degrees of hybridization indicated above. The parallel design is utilised in low degrees of hybridization because a low-power electrical machine would be unable to move the vehicle, while the series architecture is used in high degrees of hybridization since the engine is used to charge the battery while driving. Table 1 shows the complete connection.

Table 1: comparison of various architectures.

		ICE	HEV				EV
			micro	mild	full	plug-in	
HEV	parallel	X	X	X	X	X	
	series-parallel			X	X		
	series			X	X		
	EV						X

#### I. DC-DC Converter

Electric motors are used in both HEV and EV vehicles and are powered by a voltage source inverter. Maintaining a low battery rated voltage is beneficial to vehicle performance since it allows for the use of fewer cells linked in series. However, a high-voltage DC bus is required for the motor since the rated voltage and the power generated by the motor are directly proportional. Furthermore, having a high-voltage is very useful in the case of permanent magnet synchronous machines.

The flux-weakening area is displaced to the high-speed zone via a DC bus. A controlled DC voltage, which results in improved motor drive performance, is another benefit of using a DC/DC converter. As a result, in order to match the differing voltage ratings of these two devices, a DC/DC

bidirectional converter is frequently put between the battery and the inverter, as shown in Fig.

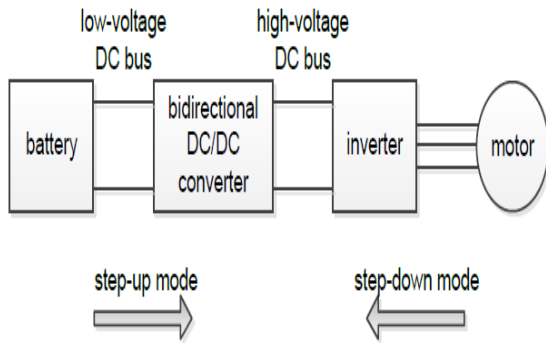

Figure 5. DC-DC Converter in traction systems.

For power transfer from the battery to the motor (step-up motor) and battery recharge during regenerative braking, this DC/DC converter must be bidirectional (step-down mode). In contrast to the DC/DC converter between the two, no galvanic separation is required.

The 12 V battery and the high voltage Boost and buck-boost converters are the most common non-isolated second-order topologies, as seen in Figures. A boost-type converter is used in hybrid electric cars. This thesis investigates a bidirectional boost converter with output filter in light of this (BBCOF). In compared to traditional boost structures, BBCOF is a competitive option as an intermediate voltage step-up stage in EVs since it has a much lower EMI level.

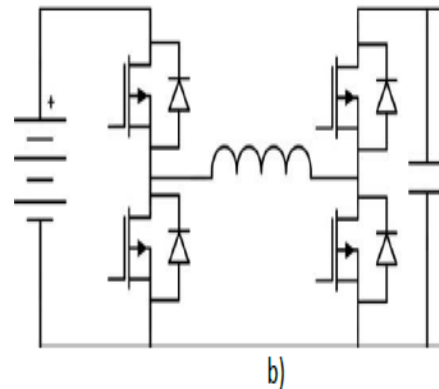
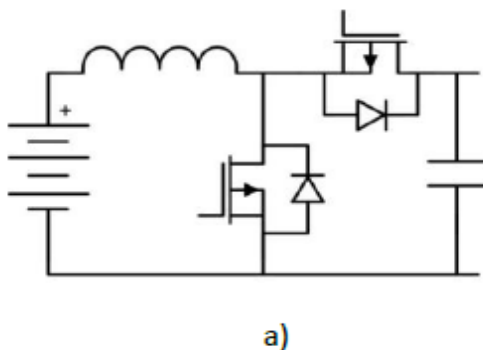

Figure 6. Basic Buck and Buck Boost Converter.

BBCOF additionally provides indirect enhanced reliability since the filter capacitors need lower capacitance components than a traditional boost converter, allowing the natural introduction of high-quality capacitors such as polypropylene, ceramic multilayer, and so on. In comparison, using a traditional boost converter would need a significantly larger capacitance for the same amount of output ripple, which would ultimately have to be implemented using electrolytic capacitors, resulting in worse reliability and higher losses.

The following fundamental design characteristics for automobile DC/DC converters are taken into account:

- light in weight
- high effectiveness
- reduced electromagnetic interference due to tiny volume
- a battery with a low current ripple

These factors must be taken into account while designing the chosen DC/DC converter, i.e. the BBCOF.

#### J. Control of DC-DC Converters

Controlling is an important aspect in the operation of any converter circuit. The output of the converter circuit depends on the control method that is employed for the control of the circuit. There are

several control mechanisms or methods available in the literature to control the DC - DC converter circuits.

Some techniques for bidirectional DC/DC converter control with a smooth transition between operating modes have recently been described. In a bidirectional DC-DC converter, a smooth transition is one that occurs between operating modes with continuous power supply and constant output voltage. The paper presents a bidirectional control for a soft-switching half-bridge DC-DC converter for electric vehicles. When going from one operating mode to the next, an extra switching pattern is included to provide smooth variation. In this paper, we show how to operate a dual active bridge in both directions. The gate signals are chosen in accordance with the demand current's sign, and the shift is likewise smooth. In a bidirectional resonant converter, a smooth mode shift strategy is achieved by switching between two separate controllers based on a given threshold of the desired current. A duty cycle is established in, and then current is permitted to flow in both directions. In order to minimise instability, two distinct controls are employed based on the current ripple.

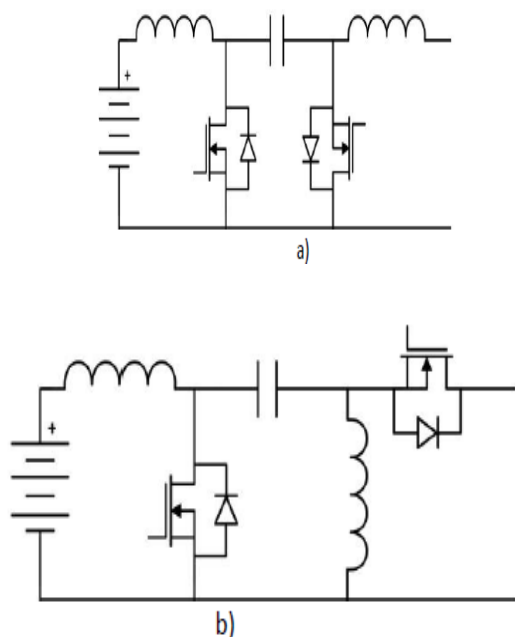

Figure 7. Cuk and Sepic converters

A sliding-mode control approach is employed in [12] to manage the output current of a bidirectional buck converter with an output LCL-filter, which leads in a stronger attenuation of the high frequency harmonics in the battery current than the standard L-filter. In both step-up and step-down modes, the battery current is controlled by a single sliding-mode controller. The output voltage, on the other hand, is not controlled.

## II. BIDIRECTIONAL DC-DC CONVERTERS

### A. Vehicle-to-Grid and Grid-to-Vehicle Power Transfer:

The batteries are vital for an electric vehicle operation. It stores the power required to drive the motor used in electrical vehicles. In order to convert the power DC-DC converter is employed. The battery in a vehicle can be also used as a distributed energy storage system. It can be used if the demand for power exists in the grid. To make it possible, it should be able to supply the power in both the directions. Which means, while charging a vehicle, it takes power from grid. While acting like a distributed storage system, it will supply the power to grid. To make it possible bidirectional power flow needs to be achieved successfully. The below figure shows the grid to vehicle power transfer process.

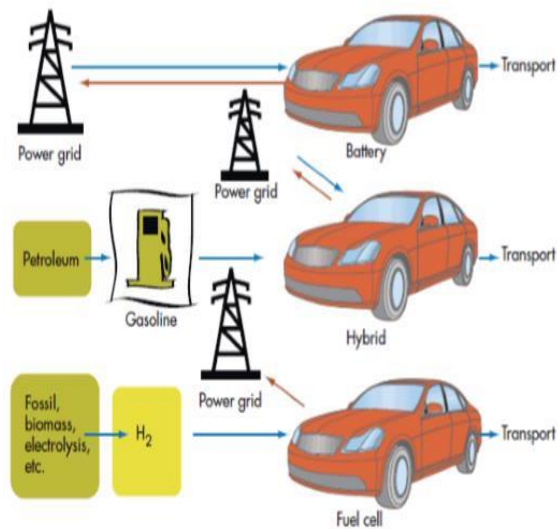

Figure 8. Grid to Vehicle power transfer.

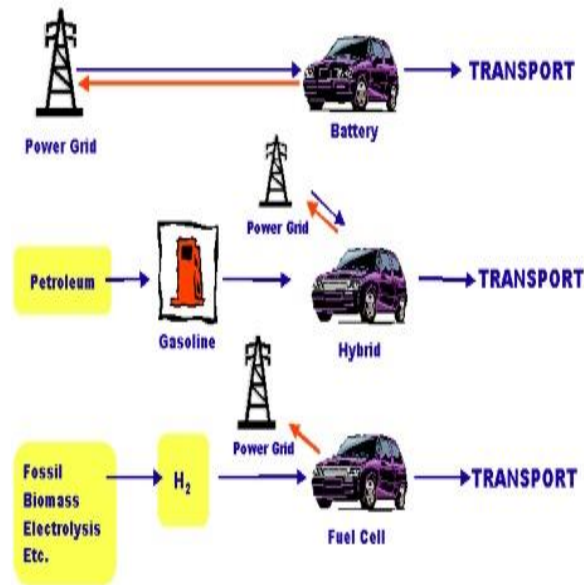

Figure 9. Vehicle to grid power transfer.

### K. Voltage fed and Current fed converters

These converters come under isolated type of converters. The type of input shows whether it is a voltage source or the current source converter. The figure below shows the voltage fed DC-DC converter. The voltage boosting in voltage fed type is achieved by the transformer used in the circuit.

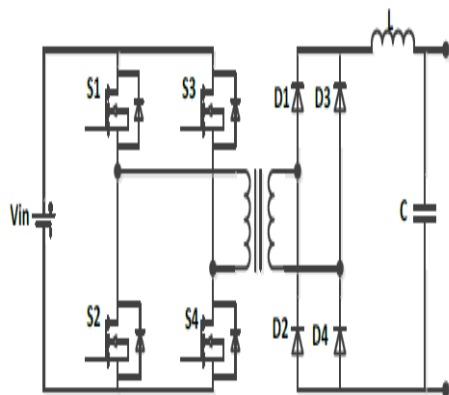

Figure 10. Conventional Voltage fed converter.

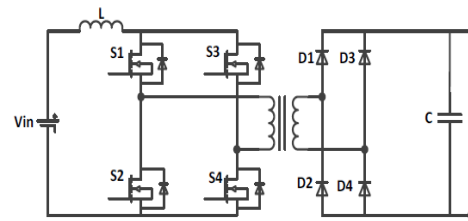

Figure 11. Conventional current fed converter.

The above figure shows the conventional current fed DC-Dc converter used for electric vehicle applications.

The other topology is also shown in the figure below, which works as the voltage fed as well as the current fed bidirectional converter. The route from V1 to V2 is a current-fed converter, whereas the opposite is a voltage-fed converter. This converter was created for hybrid automobiles to connect low battery voltages to the motor drive's high voltage dc-link. Due to the leakage inductance of the transformer, there is always a voltage spike on the switch, making the architecture unsuitable for high-power applications of many tens of kilowatts. With a few tweaks, the topology may be enhanced for usage in high-power applications. It's possible to employ a snubber circuit to lessen the voltage load on the switches.

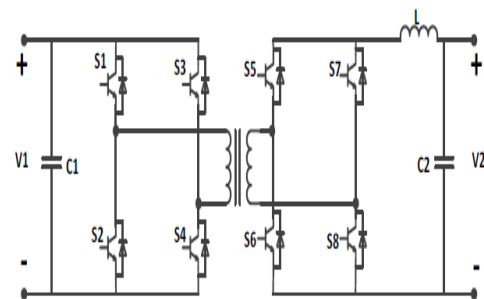

Figure 12. Bi-Directional voltage fed and current fed converter topology.

The topology based on the half bridge voltage and full bridge current is shown in the figure below.

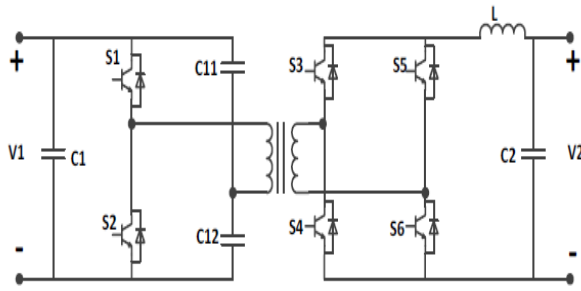

Figure 13. Bidirectional converter based on the half bridge voltage fed and the full bridge current fed.

The half bridge voltage fed and half bridge current fed bidirectional converter is shown in the below figure.

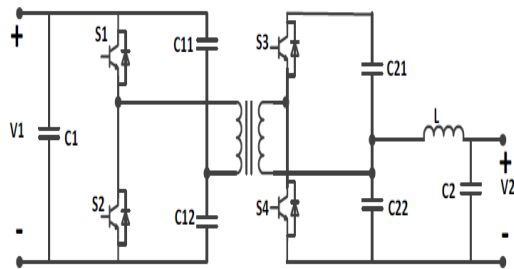

Figure 14. Half bridge voltage fed and half bridge current fed topology.

The bidirectional converter based on the combination of two full bridges is shown in the figure shown below.

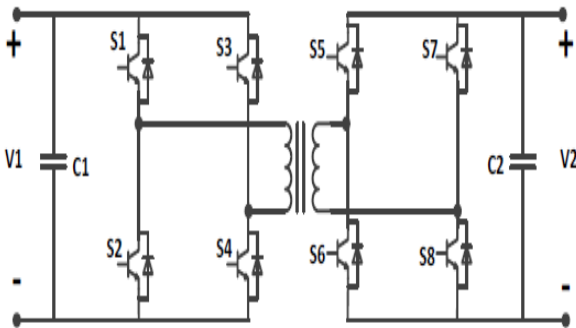

Figure 15. Bidirectional converter using two voltage full bridges.

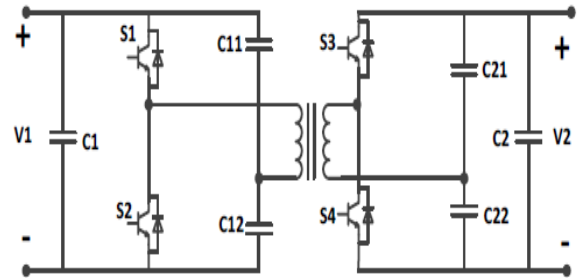

Figure 16. Using two half bridges (voltage source)

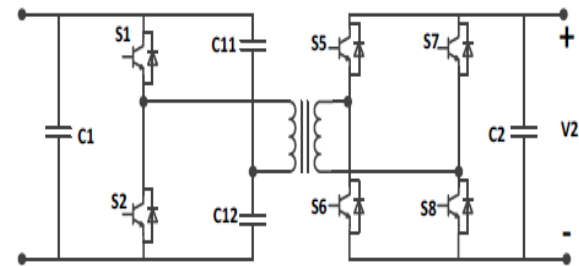

Figure 17. One half bridges and one full bridge (voltage source).

A review of the literature on various types of voltage-fed and current-fed converters aids in the selection of the best converter for PEV applications. A bi-directional DCDC converter is required in a PEV application because power is transferred from the battery for propulsion and also from the battery for charging. As a result, the input inductor in a current-fed converter may offer bi-directional power flow with reduced input current ripple, reducing the current ratings of the devices as well as the overall size of the system.

### III. CONTROL OF BIDIRECTIONAL CONVERTERS

#### A. Introduction:

In this chapter, the control method of the cascaded bidirectional DC-DC converter topology is presented. The small signal analysis is also included. The following figure show its topology.

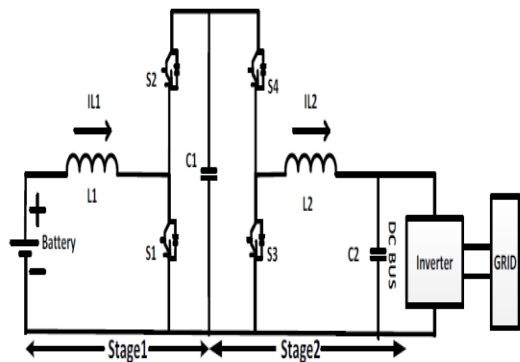
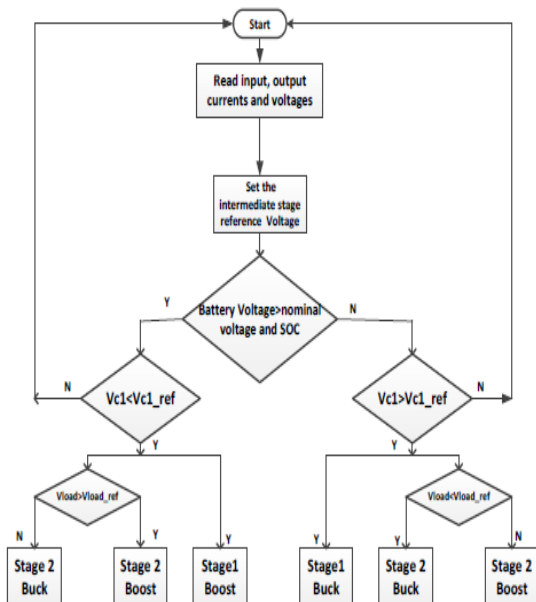

Figure 18. Cascaded topology of converter.

The above converter consists of two modes, the stage one is a BUCK mode and the stage 2 is a BOOST mode. The control of the converter depends the pulses generated by the controlling circuit.

*B. Control Algorithm:*

The detailed operation of the proposed bidirectional converter is shown in the flow chart given below. The buck and boost mode of operations are achieved in this.



**IV. SIMULATION RESULTS**

In this chapter, the simulation results of the Bi-Directional DC-DC converters are presented. All the simulations are carried out in MATLAB/SIMULINK.

*A. Specifications of the Simulation model:*

- DC bus voltage = 300 V
- Battery Voltage = 120 V
- Battery Rating = 800 Ah
- Maximum value of ripple is 0.623.

The simulations are performed for the following two cases mentioned.

*Case – 1:*

Power is supplied to the battery (battery is charging and it will take the current, so current is positive)

*Case – 2:*

Power is supplied from the battery (battery is supplying the power, current in this case is negative)

The simulation circuit in MATLAB/SIMULINK, and the waveforms obtained are shown below.

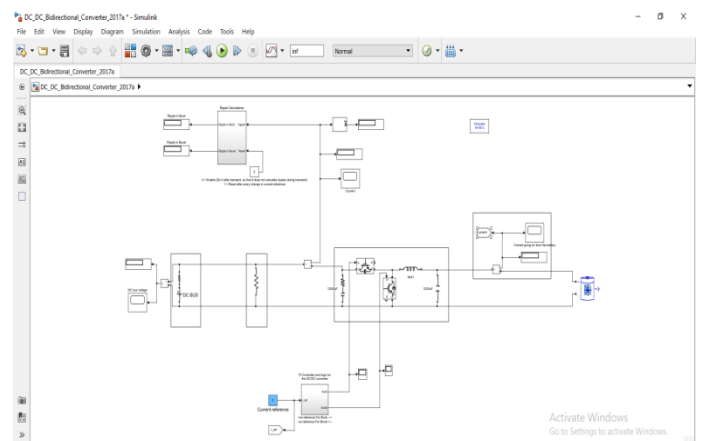

Figure 19. Simulation of a bidirectional DC-DC converter for battery charging



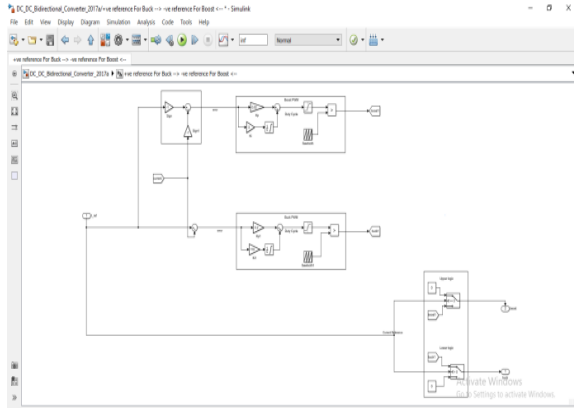

Figure 20. PI controller for the dc-dc converter

The above two figures shows the main circuit topology of the bidirectional converter and the PI controller logic used to control the converter.

**B. Waveforms for Case 1:**

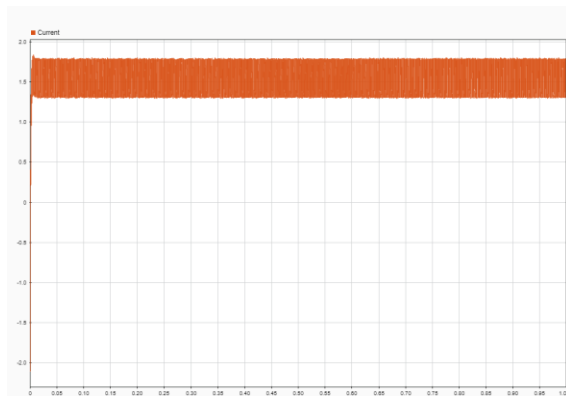

Figure 21. Current flowing in to the battery (Battery is charging)

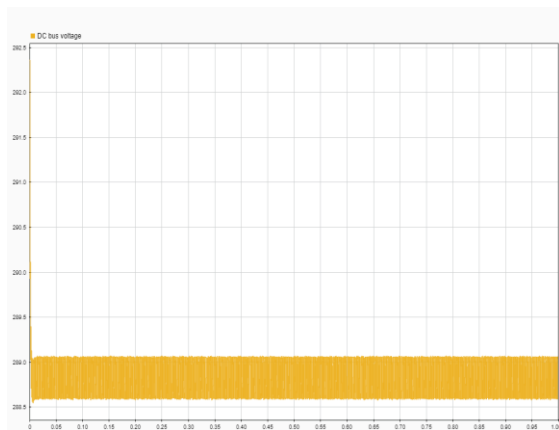

Figure 22. DC bus voltage waveform

**C. Waveforms for Case 2:**

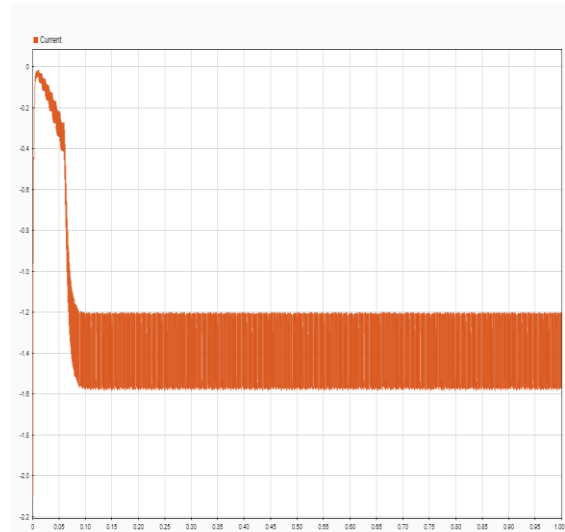

Figure 23. Current flowing out from the battery (Battery is supplying power in reverse direction).

**V.CONCLUSION**

In this work, the following conclusions are made.

- The bidirectional DC-Dc converter is simulated for the electrical vehicle application.
- The buck boost topology is simulated in bidirectional mode
- The ripple is reduced with the present controller.
- The PI controller is designed to reduce the ripple.

**VI. FUTURE SCOPE**

Following aspects are left as future scope of the project

- Advanced controllers like sliding mode control or model predictive controller can be implemented.
- The proposed converter can be redesigned for high power capacity.

**REFERENCES**

[1] M. Guarnieri, "When Cars Went Electric, Part One [Historical]," *Industrial Electronics Magazine, IEEE*, vol. 5, pp. 61-62, 2011.

- [2] M. Guarnieri, "When Cars Went Electric, Part 2 [Historical]," *Industrial Electronics Magazine, IEEE*, vol. 5, pp. 46-53, 2011.
- [3] C. C. Chan, "The Rise & Fall of Electric Vehicles in 1828&#x2013;1930: Lessons Learned [Scanning Our Past]," *Proceedings of the IEEE*, vol. 101, pp. 206-212, 2013.
- [4] K. Rajashekara, "Present Status and Future Trends in Electric Vehicle Propulsion Technologies," *Emerging and Selected Topics in Power Electronics, IEEE Journal of*, vol. 1, pp. 3-10, 2013.
- [5] R. K. Dixon, E. McGowan, G. Onysko, and R. M. Scheer, "US energy conservation and efficiency policies: Challenges and opportunities," *Energy Policy*, vol. 38, pp. 6398-6408, 2010.
- [6] T. R. Hawkins, B. Singh, G. Majeau-Bettez, and A. H. Strømman, "Comparative Environmental Life Cycle Assessment of Conventional and Electric Vehicles," *Journal of Industrial Ecology*, vol. 17, pp. 53-64, 2013.
- [7] E. J. Cairns and P. Albertus, "Batteries for Electric and Hybrid-Electric Vehicles," *Annual Review of Chemical and Biomolecular Engineering*, vol. 1, pp. 299-320, 2010.
- [8] A. Ajanovic and R. Haas, "Technological, ecological and economic perspectives for alternative automotive technologies up to 2050," in *Sustainable Energy Technologies (ICSET), 2012 IEEE Third International Conference on*, 2012, pp. 129-134.
- [9] N. Hill, C. Brannigan, R. Smokers, A. Schroten, H. v. Essen, and I. Skinner, "Developing a better understanding of the secondary impacts and key sensitivities for the decarbonisation of the EU's transport sector by 2050," European Commission Directorate-General Climate Action and AEA Technology plc, 2012.
- [10] D. Anair and A. Mahmassani, "State of charge: Electric vehicles' global warming emissions and fuel-cost savings across the United States," *Union of Concerned Scientists Report*, 2012.
- [11] O. Lopez-Santos, L. Martinez-Salamero, G. Garcia, H. Valderrama-Blavi, and D. O. Mercuri, "Efficiency analysis of a sliding-mode controlled quadratic boost converter," *Power Electronics, IET*, vol. 6, pp. 364-373, 2013.
- [12] Nissan, *2011 LEAF Owner's Manual*, 2011.
- [13] M. D. Galus, R. A. Waraich, F. Noembrini, K. Steurs, G. Georges, K. Boulouchos, K. W. Axhausen, and G. Andersson, "Integrating Power Systems, Transport Systems and Vehicle Technology for Electric Mobility Impact Assessment and Efficient Control," *Smart Grid, IEEE Transactions on*, vol. 3, pp. 934-949, 2012.
- [14] C. C. Chan, A. Bouscayrol, and K. Chen, "Electric, Hybrid, and Fuel-Cell Vehicles: Architectures and Modeling," *Vehicular Technology, IEEE Transactions on*, vol. 59, pp. 589-598, 2010.
- [15] K. Rajashekara, "Parallel between More Electric Aircraft and Electric/Hybrid Vehicle Power Conversion Technologies," *Electrification Magazine, IEEE*, vol. 2, pp. 50-60, 2014.
- [16] A. Emadi, L. Young Joo, and K. Rajashekara, "Power Electronics and Motor Drives in Electric, Hybrid Electric, and Plug-In Hybrid Electric Vehicles," *Industrial Electronics, IEEE Transactions on*, vol. 55, pp. 2237-2245, 2008.

## **AUTHORS PROFILE**

Mrs. G. Madhuri is working as an assistant professor in the department of EEE , Vignan institute of technology and science. She obtained B.tech and M.tech (Power system engineering) Degree Frome Aacharya Nagarjuna University in 2010 to 2012 respectively. She has more than 8years experience in various colleges and 7 generals and 2 conferences. Area of interest in Power system, Power system operation and control, Electro Magnetic field (EMF) . She is member of (IAENG) International Association of Engineering.

Mr. D. Bhanu chandar is pursuing M.tech (power electronics and electrical drives ) in Vignan institute of technology and science Hyderabad ,He obtained B.tech in (Electrical and electronics engineering)